

PLANTA DE FÔRMAS CX D'AGUA
ESC. 1:50

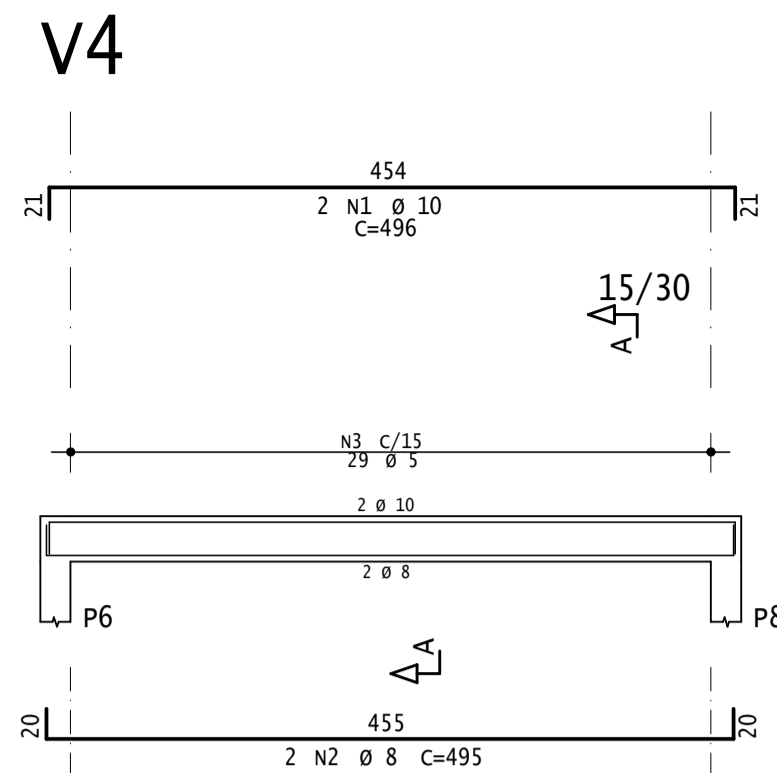

Corte A

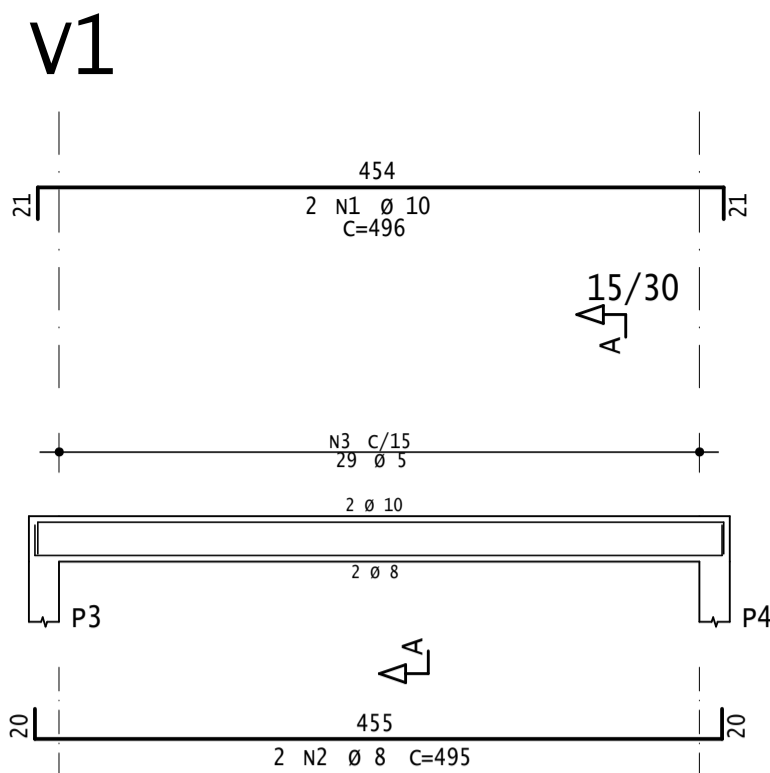
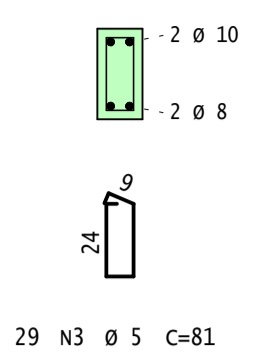

Corte A

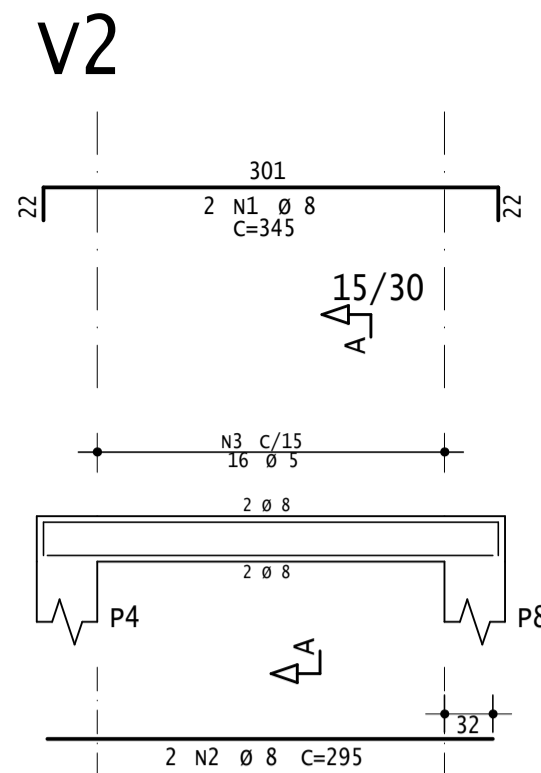
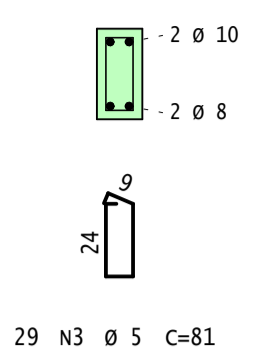

Corte A

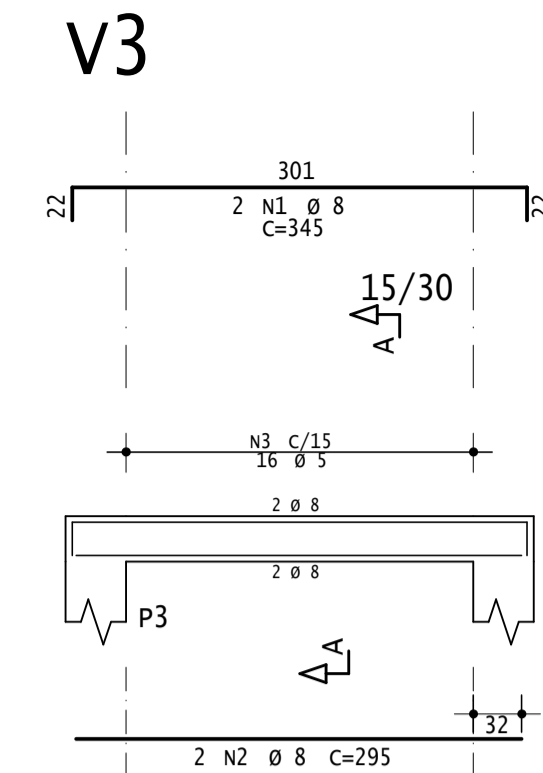
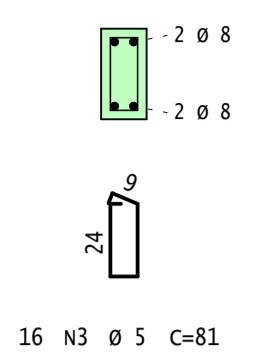

Corte A

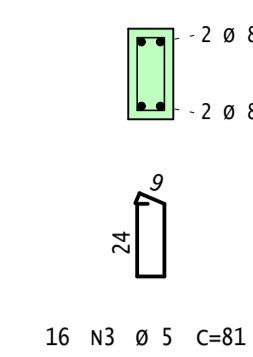

AÇO	POS	BIT	QUANT	COMPRIMENTO	
				UNIT	TOTAL
Planta Escada-1 - Primeiro					
50A	1	8	7	156	1092
50A	2	6.3	11	156	1716
50A	3	8	7	--VAR--	1225
50A	4	8	7	--VAR--	1225
50A	5	10	6	519	3114
50A	6	8	61	137	8357
50A	7	8	7	171	1197
50A	8	8	7	198	1386
50A	9	12.5	7	503	3521
50A	10	8	7	460	3220
50A	11	10	8	187	1496
50A	12	10	6	437	2622
50A	13	10	15	112	1680
50A	14	8	10	426	4260
50A	15	6.3	15	112	1680
50A	16	8	6	209	1254
V1					
50A	1	10	2	496	992
50A	2	8	2	495	990
60A	3	5	29	81	2349
V2					
50A	1	8	2	345	690
50A	2	8	2	295	590
60A	3	5	16	81	1296
V3					
50A	1	8	2	345	690
50A	2	8	2	295	590
60A	3	5	16	81	1296
V4					
50A	1	10	2	496	992
50A	2	8	2	495	990
60A	3	5	29	81	2349

RESUMO DE AÇO			
AÇO	BIT	COMPR	PESO
	mm	m	kgf
60A	5	73	11
50A	6.3	34	8
50A	8	278	110
50A	10	109	67
50A	12.5	35	34
Peso Total	60A =		11 kgf
Peso Total	50A =		219 kgf

Planta Escada-1 - Primeiro

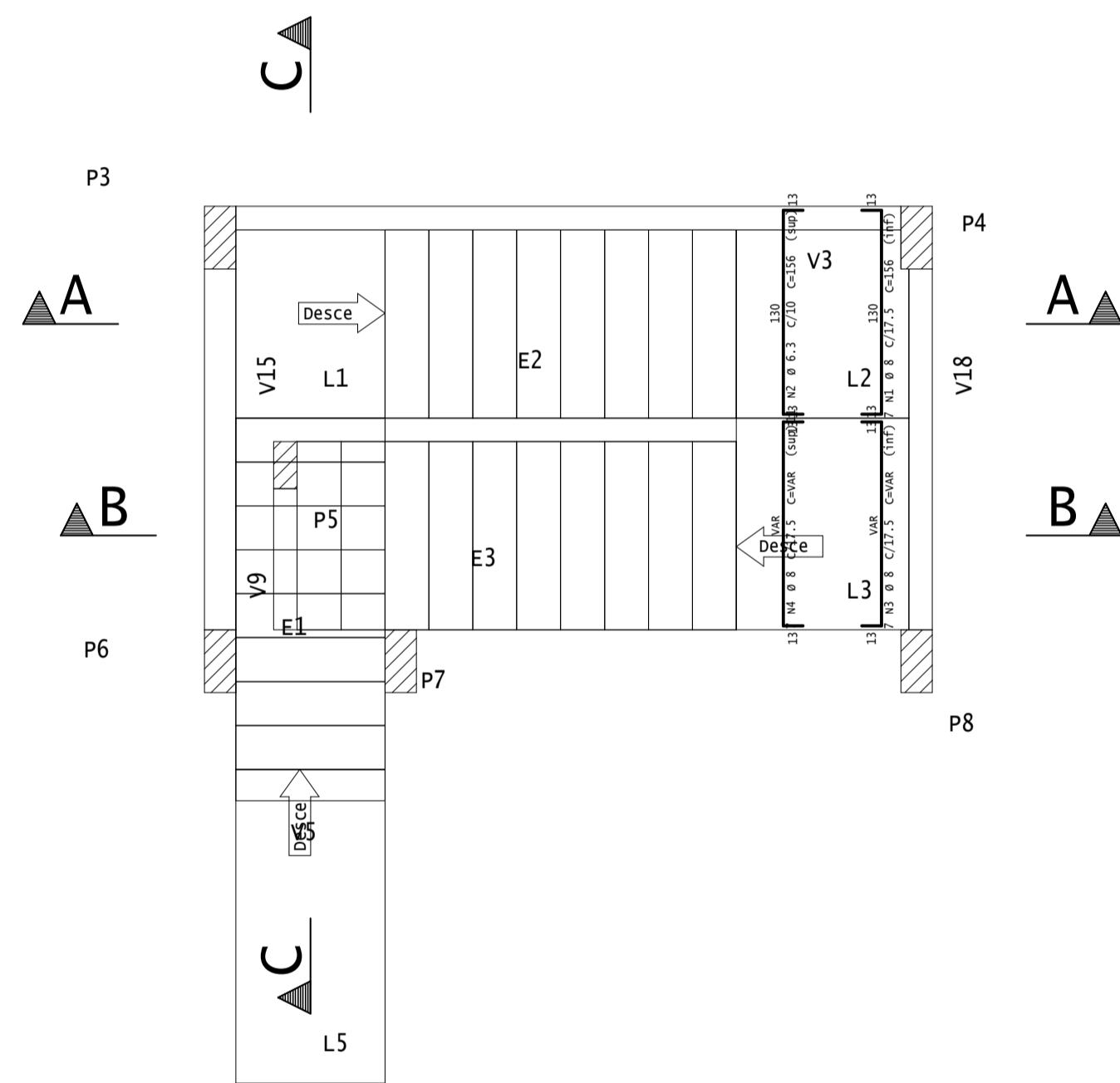

Corte A-A

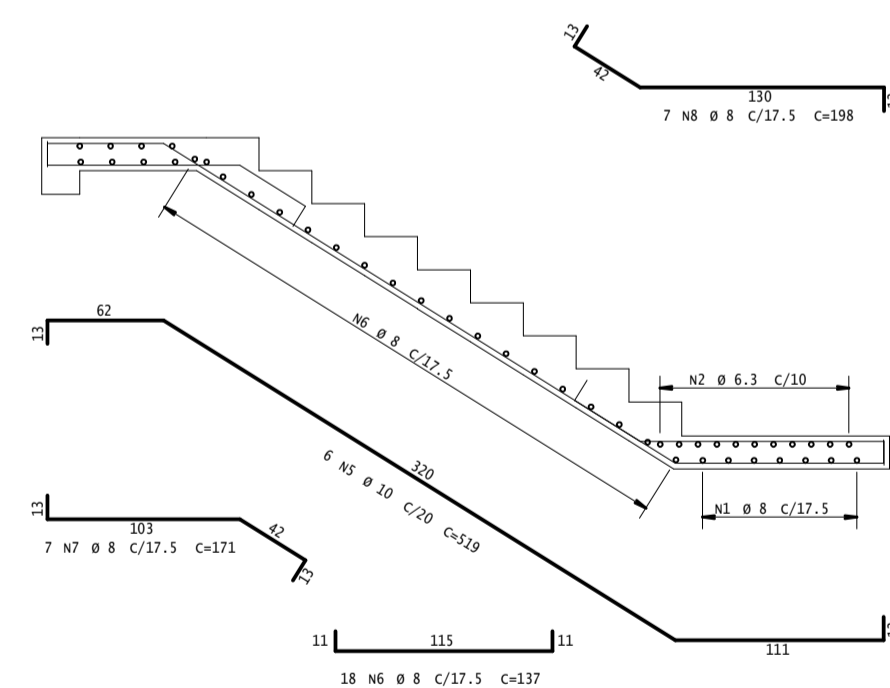

Corte B-B

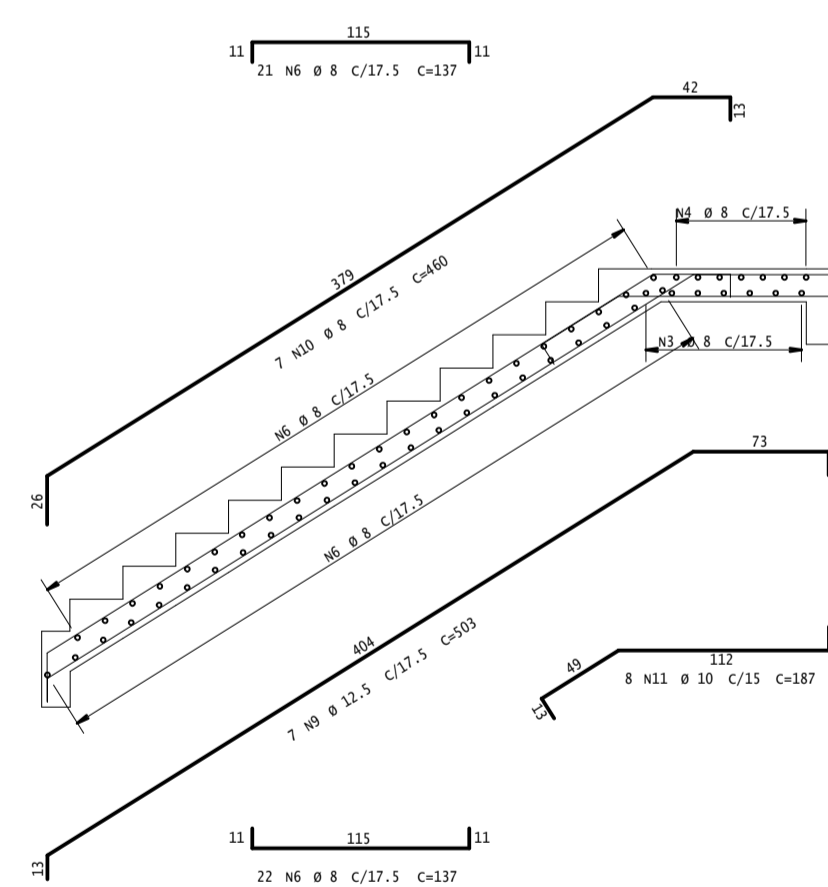

Corte C-C

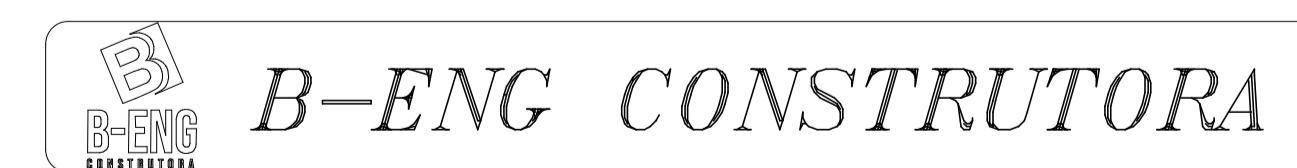
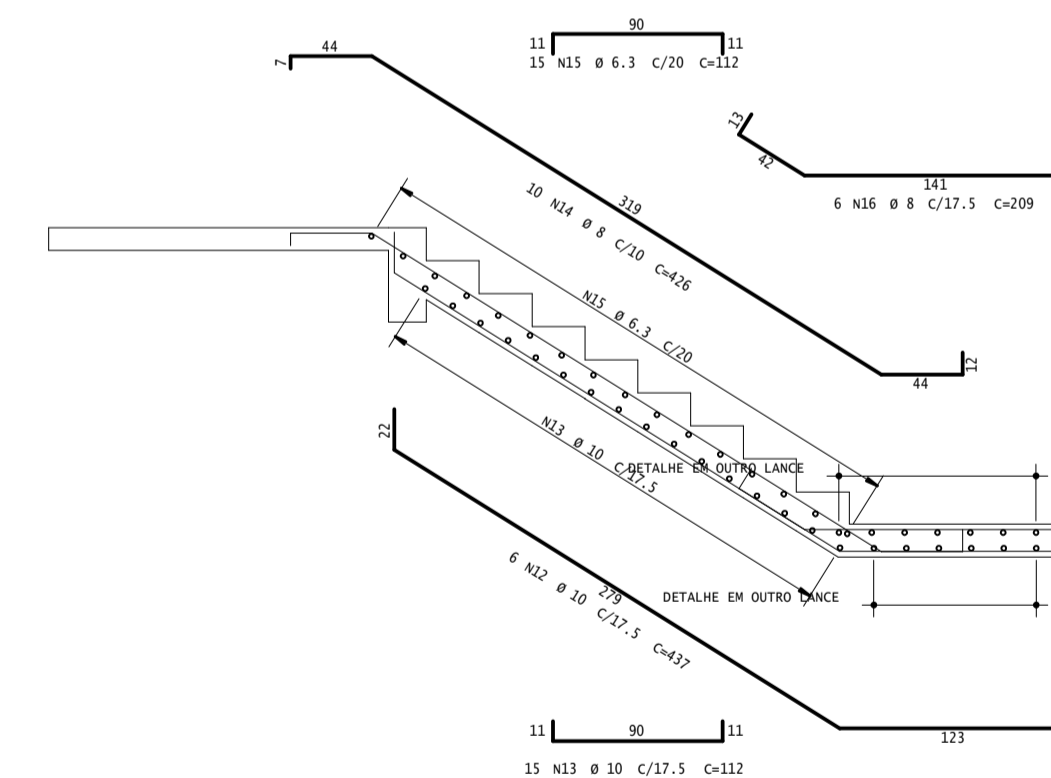

CONCRETO fck = 25 MPa ECS = Ver na Planta	OBRA N.º 0001
CLIENTE PREFEITURA DE NOVA ESPERANÇA DO SUDOESTE	OBRA ESTADIO MUNICIPAL
TITULO PLANTA DE FÔRMAS CX D'AGUA DET. VIGAS CX D'AGUA / DET. ESCADA	009
Planta Escada-1 - Primeiro v1 / v2 / v3 / v4	REV. N.º 00
DATA 27/10/2023	ESCALA Indicada
DESENHO EST-ATI-FOR-009-R00	COORD. ENC.º GUILHERME BIESEK